

# Standard DS1000 ( DS500 + DS500A )

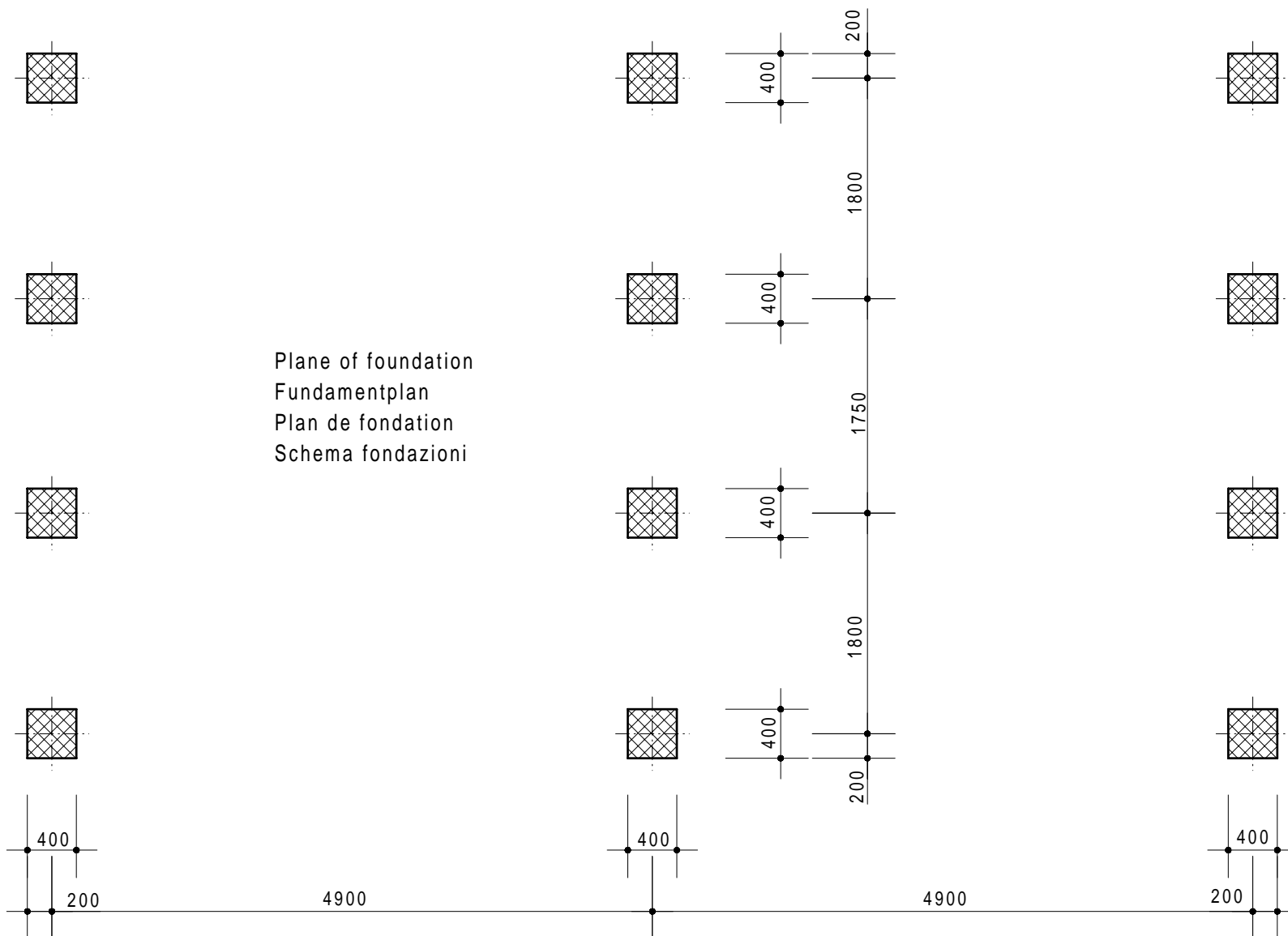
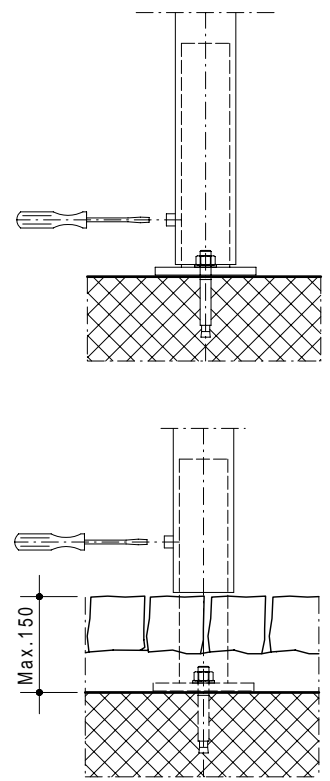
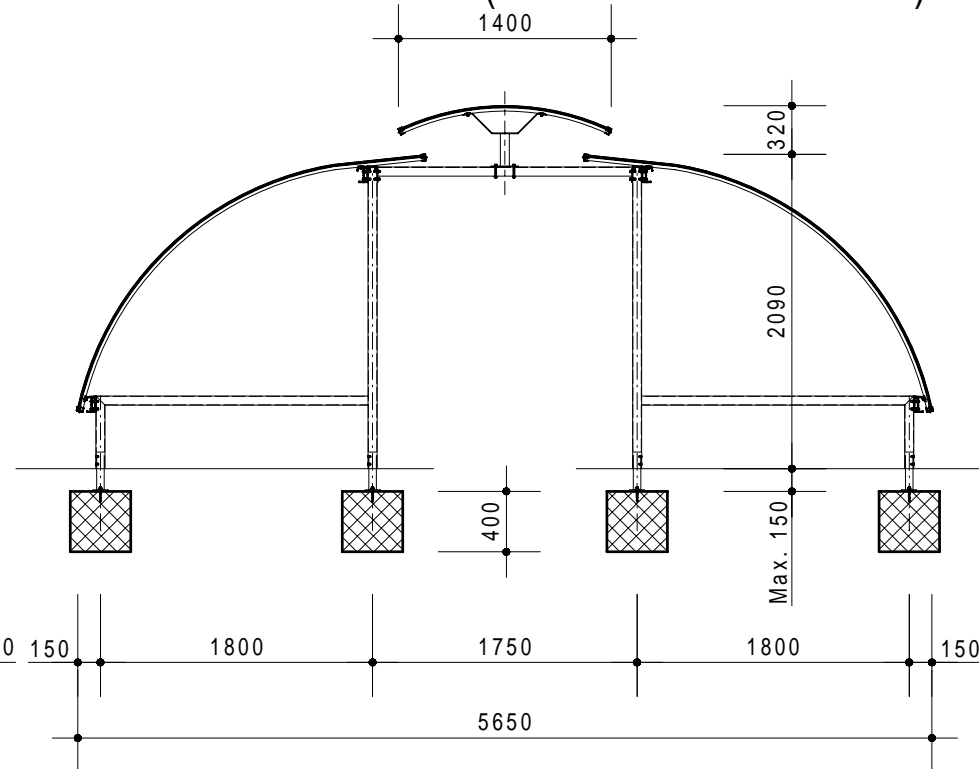

Plane of foundation  
Fundamentplan  
Plan de fondation  
Schema fondazioni

ON REQUEST - AUS ANFRAGE - SUR DEMANDE - SU RICHIESTA

Wall side - Seitenwände  
Finition laterales - Pareti laterali

Holder - Velohalter  
Support - Supporti

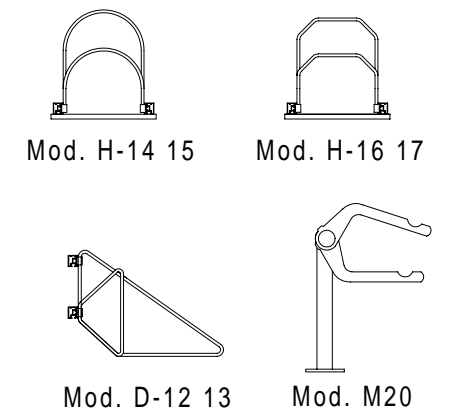
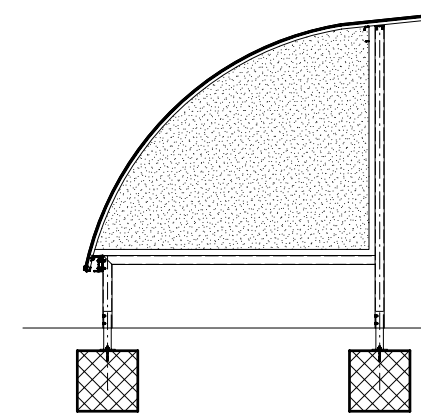

Trattamento: Ferro zincato a bagno		Alu ossidato naturale	N° pezzi
Committente:			N° ordine
Modello: STANDARD DS	Materiale: FERRO - STAHL		Data: Sett. 05
Descrizione COPERTURA CICLI E MOTOCICLI " STANDARD DS "			Disegnato: GB
ÜBERDACHUNGEN FAHRRADRÄDER UND MOTORRÄDER " Standard DS "			Scala: ---

**KERNAG SA** FÜR VERKEHRSSICHERHEIT  
POUR SÉCURITÉ DE TRAFIC  
Weberrütstrasse 9  
8833 Samstagern  
T 044 783 22 88 F 044 783 22 87  
info@kernag.ch www.kernag.ch

N° dis. / Articolo

## Standard DS1000