

Standard DS2000
(DS500 + DS500A + DS500A + DS500A)

Plane of foundation
Fundamentplan
Plan de fondation
Schema fondazioni

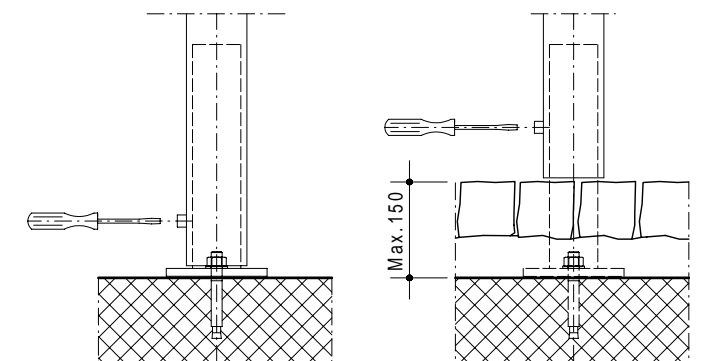

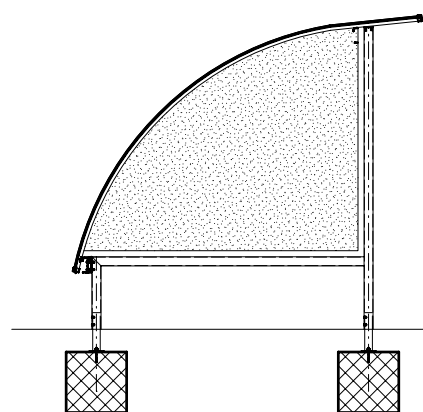

ON REQUEST - AUS ANFRAGE - SUR DOMANDE - SU RICHIESTA

Wall side - Seitenwände
Finition laterales - Pareti laterali

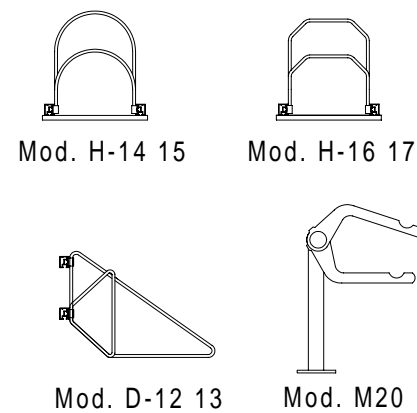

Holder - Velohalter
Support - Supporti



Trattamento: Ferro zincato a bagno		Alu ossidato naturale	N° pezzi
Committente:			N° ordine
Modello: STANDARD DS	Materiale: FERRO - STAHL		Data: Sett. 05
Descrizione COPERTURA CICLI E MOTOCICLI " STANDARD DS "			Disegnato: GB
ÜBERDACHUNGEN FAHRRÄDER UND MOTORRÄDER " Standard DS "			Scala: ---
 FÜR VERKEHRSSICHERHEIT POUR SÉCURITÉ DE TRAFIC		Weberrütstrasse 9 8833 Samstagern T 044 783 22 88 F 044 783 22 87 info@kernag.ch www.kernag.ch	N° dis. / Articolo STANDARD DS2000